

# ELECTRONIC IGNITION TRANSFORMERS FOR PERMANENT OPERATION

## Type TC....S.

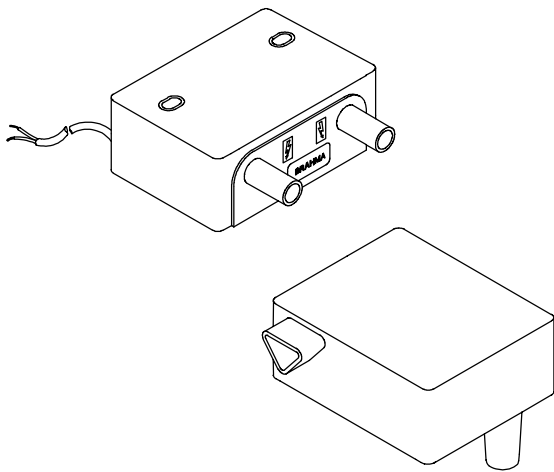

### DESCRIPTION

This range of electronic ignition transformers is characterized by extremely limited overall dimensions and is particularly suitable to equip water cleaners, forced draught burners for gas and light or heavy oil, for civil and industrial applications.

The working principle is due to the generation of high frequency voltage by means of an electronic oscillator; the resulting voltage is then increased by using a winding with ferrite nucleus. In this way it is possible to reach output voltage values up to 15 KV.

All types can be supplied with filter to minimize the emission of electromagnetic interference. In this way this series of electronic transformers is in compliance with the directive 89/336/EEC without the use of external filters.

### FEATURES

Followings are the main features of this range of transformers:

- **available with inbuilt anti-emission filter;**
- 100% duty cycle;
- limited weight and overall dimensions;
- high efficiency and ignition power;
- low consumption;
- single pole or dual pole high voltage output;
- different fixing and connecting systems.

## TECHNICAL DATA

	TC1...S	TC1...SF	TC2...S	TC2...SF
Number of poles	1	1	2	2
Output peak voltage KV (1)	15	15	2x10	2x10
Output effective voltage KV (1)	9	9	2x5	2x5
Output peak current mA (2)	45	45	55	55
Output effective current mA (2)	15	15	18	18
Output voltage frequency kHz (1)	6	6	8.5	8.5
Output voltage frequency kHz (2)	10	10	12	12
Inbuilt filter		•		•
Consumption VA (3)	25	25	30	30

- (1) Open-circuit secondary with 30pF charge.  
 (2) Short-circuit secondary.  
 (3) 10mm discharge distance.

- **Supply voltage:** 220/240V-50/60Hz  
on request: 110/120V-50/60Hz
- **Operating cycle:** 100%
- **Operating temperature range:** -10°C +60°C
- **Recommended distance between the electrodes:** 3÷5 mm
- **Max. ignition cable length:** 1.5 m
- **Standard supply cable length:** 560 mm
- **Weight:** about 370 g

## CONSTRUCTION

The working principle based on the use of a high frequency electronic oscillator has allowed to realize a device with limited dimensions and weight, but with high ignition power. The electronic circuit and the transformer with ferrite nucleus are bathed in a special kind of resin with good thermal conductivity and a specific coefficient of expansion, which grants high resistance to temperature variations and to the overload due to protracted working.

An inbuilt varistor protects the appliance from possible voltage transients in the electric network.

The transformers of this series are available in different executions as regards the number of poles, the position of the isolators, the type of connection and output and the presence of anti-emission filter; on this subject, see the following schemes:

standard versions:

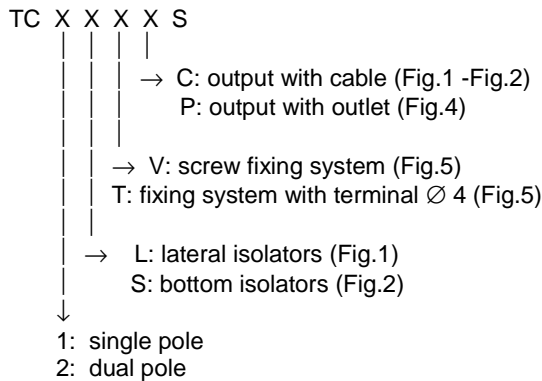

Versions with inbuilt anti-emission filter:

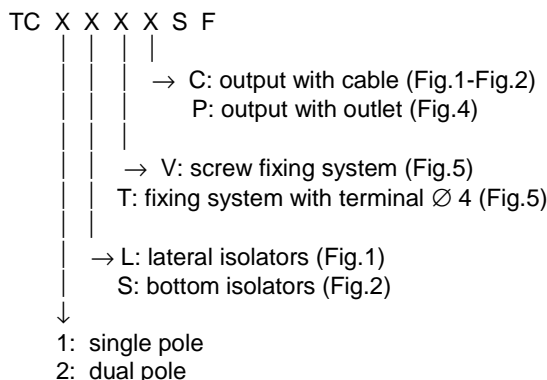

For instance, the denomination TC2LVPSF indicates that this type of transformer is designed for permanent operation and is provided with two lateral isolators, screw fixing system, output with outlet and anti-emission filter.

## OVERALL DIMENSIONS

Fig.1 and Fig.2 show the main overall dimensions of these transformers.

To fix the transformers screws type M4x40 or M5x40 must be used; the oval fixing holes permit a variation of the wheel base between 57 mm and 64 mm.

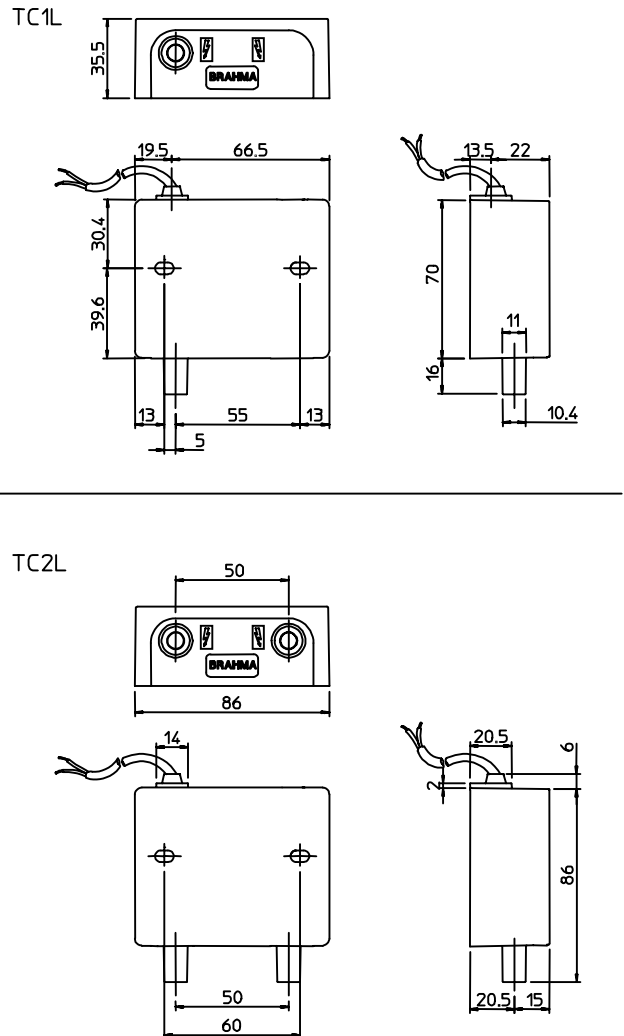
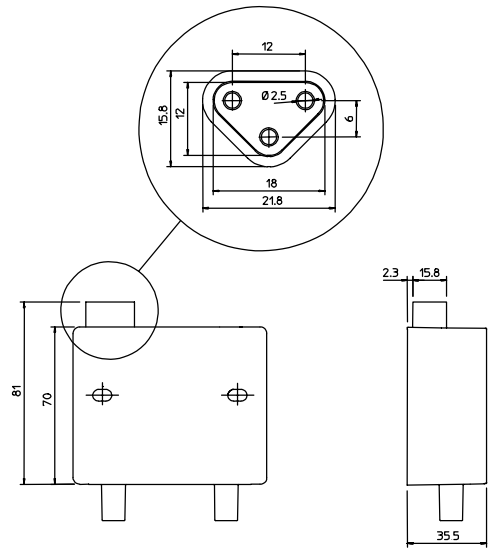
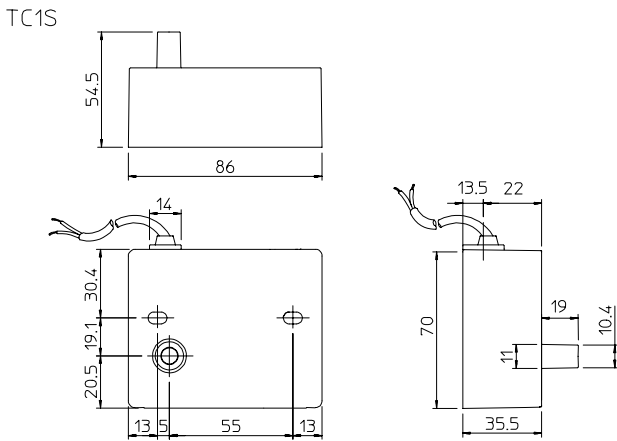

Fig.1



Type "P"

Fig.4

The connection of high voltage cables can be of two types, according to the terminals used inside the isolators: connections can be executed by means of a screw or of a cylindrical terminal with 4 mm diameter, as shown in Fig.5. All connectors, including the ones complete with cable, can be supplied on request.

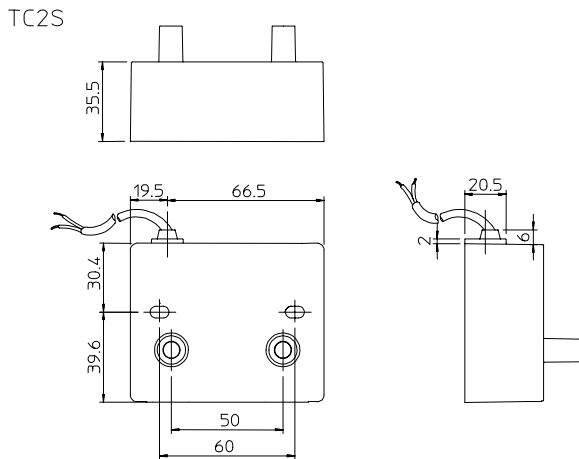
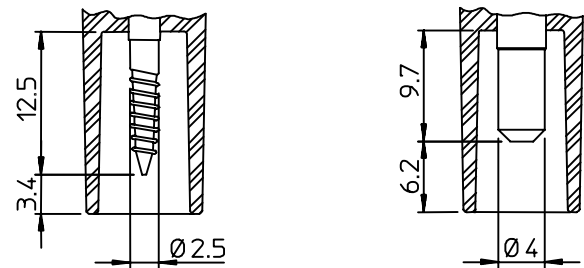

Fig.2

### CONNECTION

This range of ignition transformers has been realized in order to be used with control boxes of our own production, which can be mounted on the ignition devices by means of fixing screws type M4x45, as shown in Fig.3.

All transformers can be supplied with cable or supply outlet; see, for instance, Fig.4, which shows the dimensions of a transformer provided with supply outlet and lateral isolators.



Type "V"

Type "T"

Fig.5

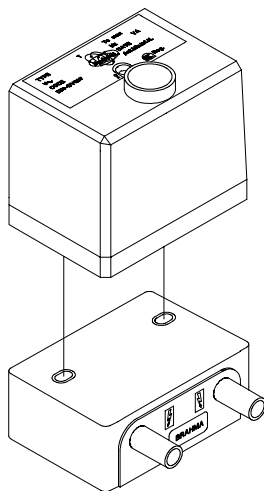

Fig.3

### INSTALLATION

- Connect and disconnect the ignition transformer only after interrupting the main supply.
- Respect the applicable national and European standards (e.g. EN 60355-1 / prEN 50165) concerning electrical safety.
- Make sure that the earth of the ignition transformer and the earth of the electrical system are well connected.
- The device can be mounted in any position.
- Avoid putting high voltage cables next to other cables.
- Grant a protection degree suitable to the application.

### ANTI-EMISSION FILTER

With particular reference to the use of ignition transformers on oil or gas burners, you will find here below some remarks about the application of these devices, resulting from the research carried out by the Brahma Testing Laboratory. This Laboratory, in compliance with EN55014 and with CISPR 16-1, is adequately equipped for the measuring of electromagnetic interference on boilers, burners, warm air generators and heating systems in general.

According to the directive 89/336/EEC, the above mentioned products are subjected to the measuring of conducted electromagnetic interference in the power network, irradiated by the supply cable; the measuring is

carried out on the basis of a frequency range from 150KHz to 30MHz in case of conducted interference, and from 30 to 300MHz in case of irradiated interference.

Electromagnetic interference is mainly due to power variations in the electric circuits (i.e. current peaks); the greater and faster these variations, the higher the interference. In this case, the main source of interference is the discharge of the ignition transformer: the irregular discharge current causes the emission of interference on a wide frequency range.

To keep the products within the limits allowed by the present standards, a special capacitive-inductive filter is generally installed in series to the main supply, in order to reduce electromagnetic interference with frequency up to 20MHz approx.. A resistor of a few K $\Omega$ s is mounted in series to the ignition electrode to reduce the interference with higher frequency, due to the high current peak generated whenever an electric arc is produced. The stronger the stray capacitance between ignition electrodes and cables and burner metal casing, the higher the current peak. The above mentioned resistor has the function of keeping the current peak as low as possible; the closer to the source of electric discharge, the greater the effectiveness of the resistor.

Besides the obvious advantage of reduced assembly costs, the fitting of an anti-emission filter inside the ignition transformer ensures the elimination of electromagnetic interference in close proximity to their source, without involving the remaining electric circuit. However remember that the anti-emission filter is not effective with frequency values > about 20MHz; in this case, if necessary, the only possible solution is to mount a resistor in series to the ignition electrode, as described above.

Finally, the following solutions are always effective to reduce the emission of electromagnetic interference:

- ignition cables should be as short as possible (this will reduce their stray capacitance and their possibility of acting as antennas, transferring electromagnetic interference to the nearby cables);
- use distributed resistance cables or mount a resistor near the electrodes (few k $\Omega$ s can reduce the current peak);
- let ignition cables follow a separate path, close to ground planes (this will reduce the influence of electromagnetic interference on the remaining electric cables);
- realize a single earth centre, preventing the earth conductors from creating circular paths .

**BRAHMA S.p.A.**

Via del Pontiere, 31  
37045 Legnago (VR)  
Tel. +39 0442 635211 - Telefax +39 0442 25683 - 635256  
<http://www.brahma.it>  
E-mail : [brahma@brahma.it](mailto:brahma@brahma.it)

 **Implementos Industriales**  
Medición y Control  
de Temperatura  
Humedad - Caudal  
Nivel y Llama

[www.implementosenlweb.com.ar](http://www.implementosenlweb.com.ar)

Tel.: (0351) 4805405

00/02/08 Subject to amendments without notice