

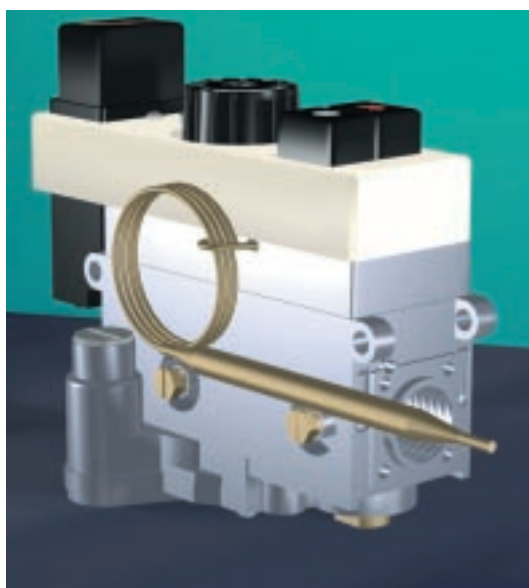

SIT Group

710 MINISIT

MULTI-FUNCTIONAL GAS CONTROL



THERMOELECTRIC FLAME SUPERVISION DEVICE

PRESSURE REGULATOR

TEMPERATURE CONTROL



MULTI-FUNCTIONAL CONTROL WITH THERMOSTAT

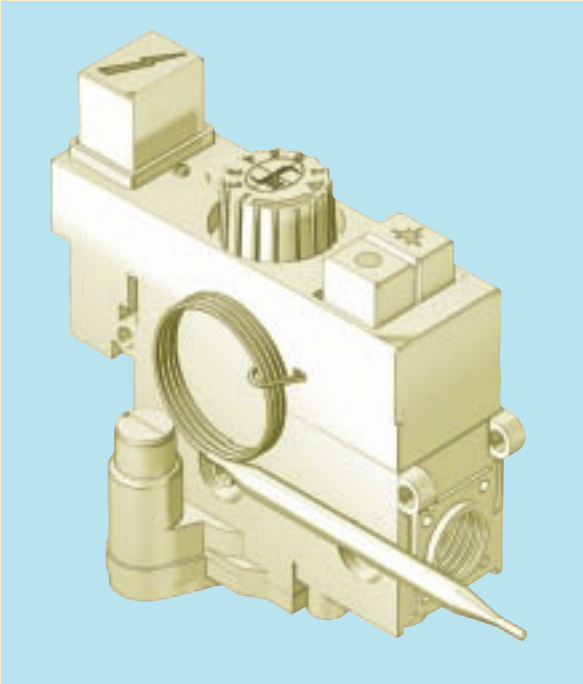

Multi-functional control incorporating thermoelectric flame supervision device with restart interlock, pressure regulator or flow adjuster, modulating thermostat with on/off snap function.

The 710 MINISIT is suitable for use with stoves, boilers, catering equipment and room heaters.

MAIN FEATURES

- Thermoelectric safety device.
- Shut-down device with pilot restart interlock.
- Direct acting thermostat with modulation between minimum & maximum setting and on/off snap function.
- Pilot gas rate adjuster.
- Pressure regulator (optional).
- Built-in cutout device to exclude the pressure regulator (if necessary).
- Flow adjuster (as an alternative to pressure regulator).
- Inlet and outlet pressure test points (optional).
- Piezo-electric igniter (optional).

Data refer to EN 126 Standard

DESCRIPTION

- | | |
|--|--|
| <ul style="list-style-type: none"> 1 Ignition button 2 Shut-down button 3 Piezo-electric ignition button (optional) 4 Temperature setting knob 5 Screw for adjusting gas flow to pilot 6 Minimum flow setting screw 7 Maximum flow setting screw (versions with flow regulator) | <ul style="list-style-type: none"> 8 Outlet pressure setting screw (versions with flow regulator) 9 Inlet pressure test point 10 Outlet pressure test point 11 Thermocouple connection 12 Pilot outlet 13 Gas inlet 14 Main gas outlet 15 Flange fixing holes (M5) 16 Fixing points 17 Thermostat bulb |
|--|--|

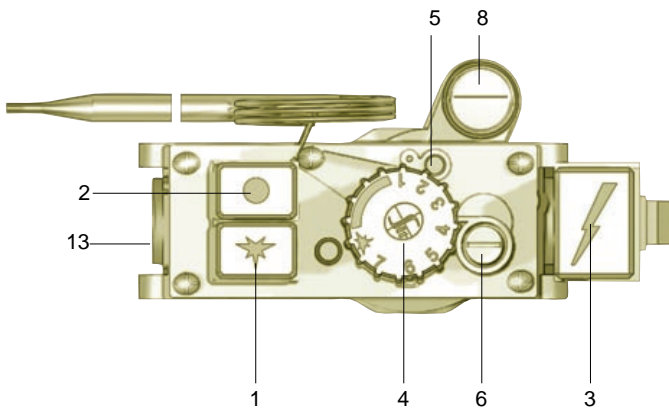

(Version with pressure regulator)

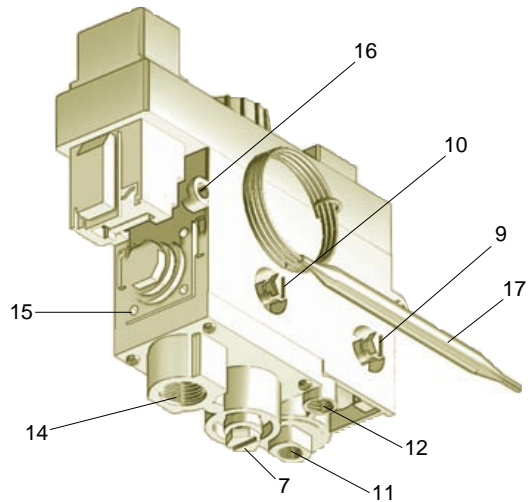

(Version with flow regulator and bottom gas outlet)

TECHNICAL DATA

- Gas connections
- Installation position
- Gas families
- Maximum gas inlet pressure
- Outlet pressure setting range (optional)
- Working temperature range
- Pressure regulator (optional)

inlet 1/2 or 3/8 - outlet 3/8 Rp ISO 7
 any
 I, II and III
 50 mbar
 3-18 mbar (15-30 mbar)
 0-80 °C
 optional class C

Thermostat range	a	b	c
8-33 °C	3	3	2
13-31 °C	2	2	2
13-38 °C	3	3	2
13-48 °C	4	4	3
21-46 °C	3	3	2
30-100 °C	9	9	5
40-72 °C	5	5	3
40-80 °C	5	5	3
100-340 °C	30	30	10

Other ranges are available on request

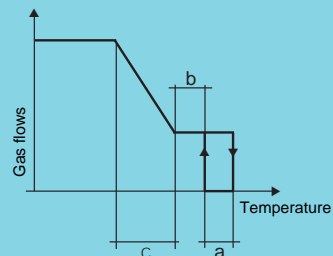

Data refer EN 126 standard

DIMENSIONS

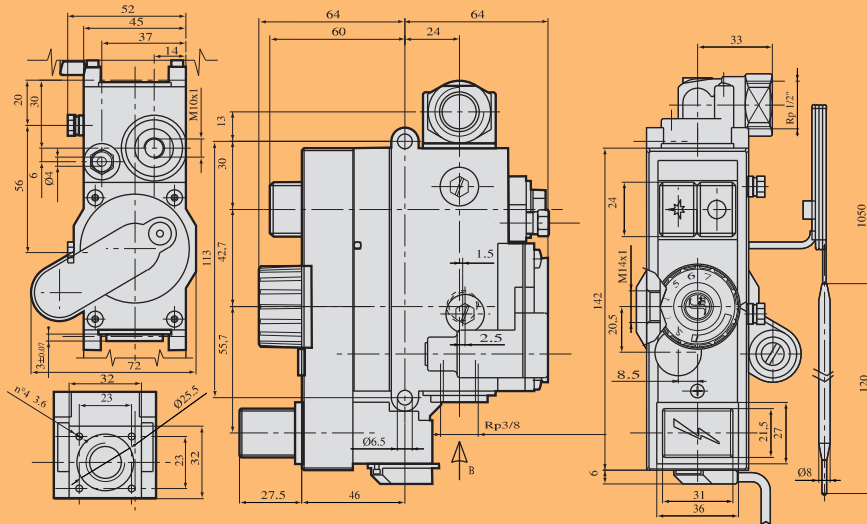

GAS FLOW AS A FUNCTION OF PRESSURE LOSS

Q [m^3/h $d=0.6$]

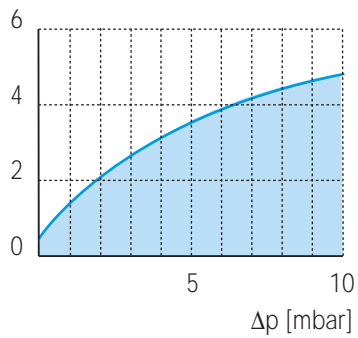

I Family ($d = 0.45$)	$Q = 3.9 \text{ m}^3/\text{h}$	$\Delta p = 5 \text{ mbar}$
II Family ($d = 0.6$)	$Q = 3.5 \text{ m}^3/\text{h}$	$\Delta p = 5 \text{ mbar}$
III Family ($d = 1.7$)	$Q = 4.4 \text{ kg/h}$	$\Delta p = 5 \text{ mbar}$

ACTUATION

Ignition

Press button  and keep it depressed. (Fig. 1)

Light the pilot burner and wait a few seconds. If the valve is fitted with a piezo-electric igniter, press button  to light the burner. (Fig. 2)

Release button  and check that the pilot flame stays on, otherwise repeat the ignition procedure.



fig. 1



fig. 2

Normal operation

Set knob to the temperature required.

The maximum temperature setting is obtained by turning the knob fully anti-clockwise. (Fig. 3)

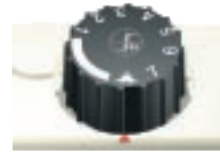

fig. 3

Pilot position (Only in those versions with  on the knob)

Turn knob fully clockwise (position 

Shut-down

Press button  right down. (Fig.4)

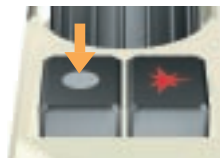
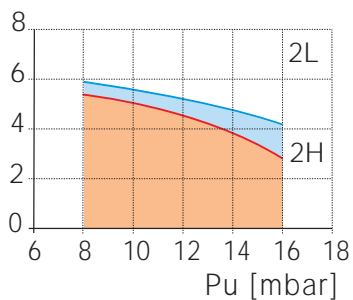

fig. 4

CAUTION: The re-start interlock device prevents the appliance from re-igniting until the flame supervision device has interrupted the gas flow. After this stage (i.e. when the magnet unit has closed) it is possible to re-ignite the appliance.

GAS FLOW SET TO EN 88

$$Q = [m^3/h \text{ d}=0.6]$$



Type of gas	Inlet pressure range (mbar)		
	Nominal	Max.	Min.
2H	20	25	17
2L	25	30	20

Outlet pressure tolerance +10% -15%

INSTALLATION

Main gas connection

The connection must be made using gas pipes with 1/2 or 3/8 inlet and 3/8 outlet Rp ISO 7. Torque: 25 Nm. Alternatively, it is possible to use a nut and olive connection for \varnothing 12 mm pipes (Codes 0.958.025 and 0.957.007) (torque 15 Nm).

Connection to the pilot burner

\varnothing 4 mm, \varnothing 6 mm or \varnothing 1/4" pipes can be used. Use appropriately sized nut and olive. Tighten to 7 Nm torque. After making the gas connection, check gas seals and efficiency of the appliance.

A COLORI

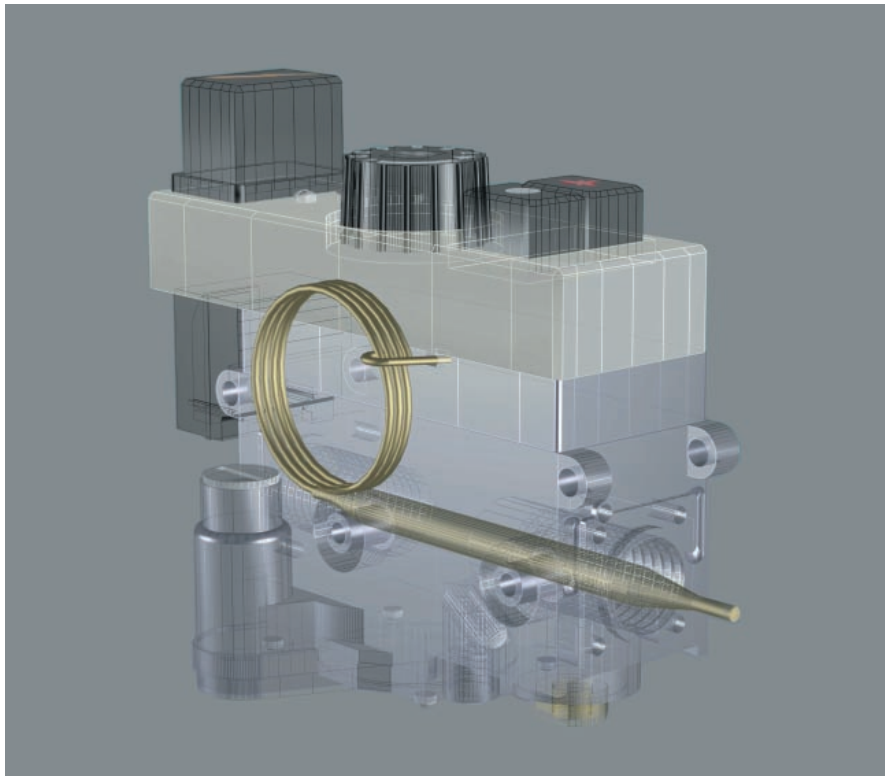

Setting the thermostat

The thermostat is calibrated and sealed at the factory.

Re-calibration is not authorised as it may adversely affect the performance of the appliance to which it is fitted and will also invalidate warranty.

Low fire adjustment

Turn the MIN screw clockwise to decrease the flow, anti-clockwise to increase it (calibrated screws available on request).

Adjusting pilot gas flow

Turn the relevant screw clockwise to decrease the flow or anticlockwise to increase it.

Adjusting the outlet pressure

(Versions with pressure regulator)

Remove the cap and turn the setting screw (A) clockwise to increase the outlet pressure or anticlockwise to reduce it.

Adjusting the outlet flow

(Versions with pressure regulator)

Remove the safety cap.

Turn the screw (B) clockwise to decrease the flow or anticlockwise to increase it.

WARNING

For Minisit operation on third family gases ensure:

- The MIN screw is replaced by a pre-drilled version MIN screw as specified by the appliance manufacturer. This screw must be screwed fully home.
- The pilot adjusting screw is un-screwed two turns from the fully closed position.
- Pressure regulator adjustment screw is screwed fully clockwise or if an output flow adjuster is fitted, it is screwed fully anti-clockwise, so that they are non-operable thereby enabling the gas supply regulator to be ineffective.

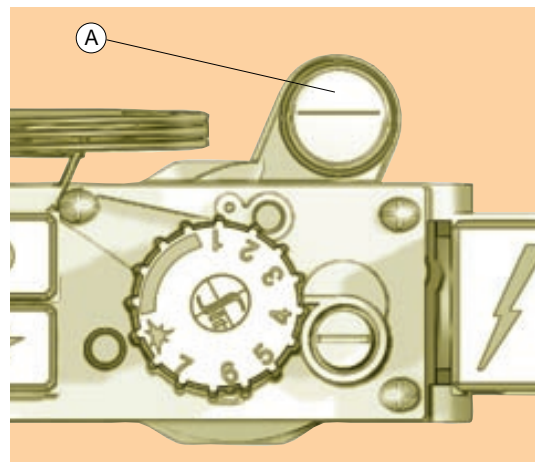

Adjusting the outlet pressure

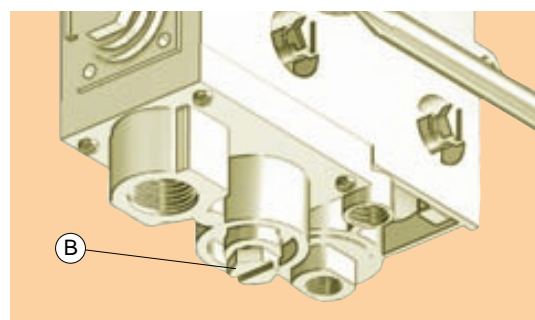

Adjusting the outlet flow



IMMAGINE
ITALIANO

Please ensure you follow all the guidelines detailed in the installation and operation manual (code 9.956.710) when installing, adjusting or operating the equipment in your possession.

Low fire adjustment

710 MINISIT

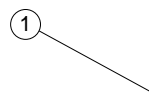

**Multi-functional control
for gas appliances
without electrical power
supply**

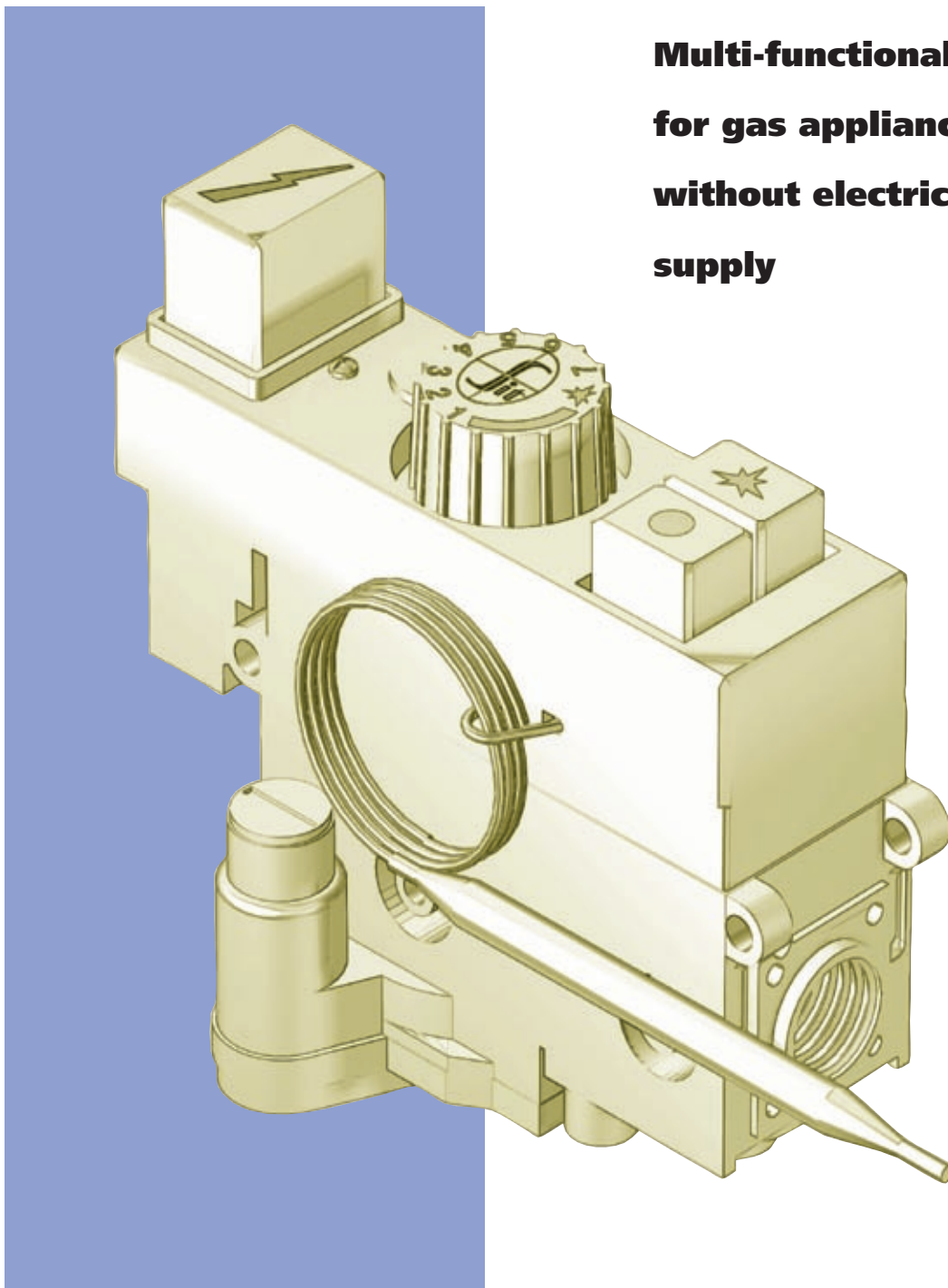

SIT La Precisa
Viale dell'Industria 31/33 35129 PADOVA - ITALY
Tel. 049/8293111 - Fax 049/8070093 - Telex 430130 SITEC I

